







PROCOOL SX80 FAN SERIES RACK MOUNT COOLING SYSTEMS

Intake Models: SX280, SX380, SX480, SX2280, SP280X and SP480X

Exhaust Models: SX280-E, SX380-E, SX480-E, SX2280-E, SP280X-E and SP480X-E



Model No.	SX280, SX280-E, 	SX380, SX380-E 	SX480, SX480-E 	SX2280, SX2280-E 
	* SP280X, SP280X-E 			*SP480X, SP480X-E 
Panel Size:	2U (19" w x 3.5" h x 1.75" d)	2U (19" w x 3.5" h x 1.75" d)	2U (19" w x 3.5" h x 1.75" d)	2U (19" w x 3.5" h x 1.75" d)
Panel color/material:	Black/metal	Black/metal	Black/metal	Black/metal
Fan Size:	80mm x 80mm x 25mm	80mm x 80mm x 25mm	80mm x 80mm x 25mm	80mm x 80mm x 25mm
Number of Fans:	2	3	4	4
Fan Speed (per fan):	1600 RPM	1600 RPM	1600 RPM	1600 RPM
Air Flow Direction	INTAKE (*E = EXHAUST)	INTAKE (*E = EXHAUST)	INTAKE (*E = EXHAUST)	INTAKE (*E = EXHAUST)
Air Flow (combined):	64 CFM	96 CFM	128 CFM	128 CFM
Static Pressure (per fan):	2.89mm H ₂ O	2.89mm H ₂ O	2.89mm H ₂ O	2.89mm H ₂ O
Noise (combined):	17 dBA	19 dBA	20 dBA	20 dBA
Thermistor Probe length	24"	24"	24"	24"
Grills/Guards:	Black Wire	Black Wire	Black Wire	Black Wire
Bearings:	Fluid Dynamic	Fluid Dynamic	Fluid Dynamic	Fluid Dynamic
Power Supply:	100-240 VAC - 12 VDC	100-240 VAC - 12 VDC	100-240 VAC - 12 VDC	100-240 VAC - 12 VDC
Power Supply Plug:	NEMA 1-15 – 2.1mm	NEMA 1-15 – 2.1mm	NEMA 1-15 – 2.1mm	NEMA 1-15 – 2.1mm
Power Supply Cable:	36"	36"	36"	36"
Current draw:	0.18A	0.27A	0.36A	0.36A
Power consumption:	2.16w	3.24w	4.32w	4.32w
Weight	2 lbs.	2 lbs.	2 lbs.	2 lbs.
Operating Temperature	-10°/+70° C	-10°/+70° C	-10°/+70° C	-10°/+70° C
Storage Temperature	-40°/+80° C	-40°/+80° C	-40°/+80° C	-40°/+80° C

- Specifications are subject to change without notice.

Model SX80 Silent Fan

The SX80 series of fans provide the quietest cooling solution. Recommended where absolutely silent cooling is required. The SX80 fans provide 32 CFM of airflow while running at a whisper quiet 14 dBA. The special blade design creates more airflow with less noise than conventional ball bearing type fans.

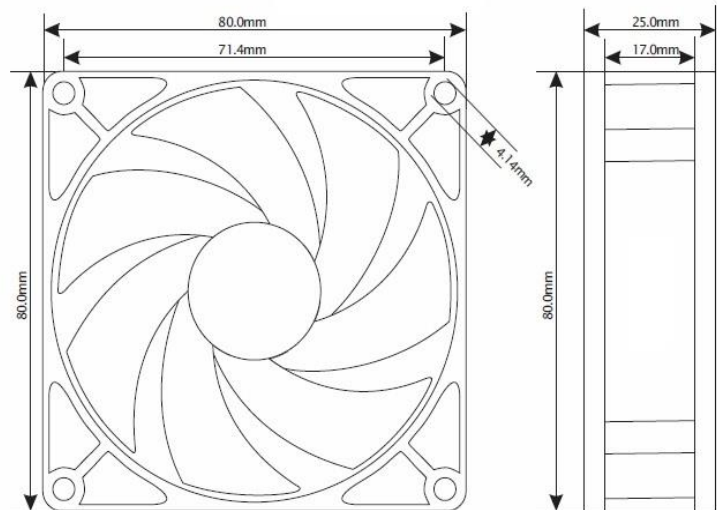

SXT80 Specifications	
Rated Voltage	12.0 vDC
Voltage Range	10.2~13.8 vDC
Rated Current	0.17 A
Rated Power	2.04 w
Rated Speed	<1600 RPM
Airflow	<32 CFM
Static Pressure	<2.89 mm H ² O
Noise Level, 1m, xyz axes avg	<14 dBA
Noise Level, 1m, z axis	<17 dBA
Operating Temperature	-10°/+70° C
Storage Temperature	-40°/+80° C
Bearing	Fluid Dynamic
Weight	2.8 oz.

MTBF Hours		
Temperature	L50	L10
30° C	294293	114223
40° C	203982	64072
50° C	144631	37224
60° C	104689	22336
70° C	77219	14012

Pressure Curve

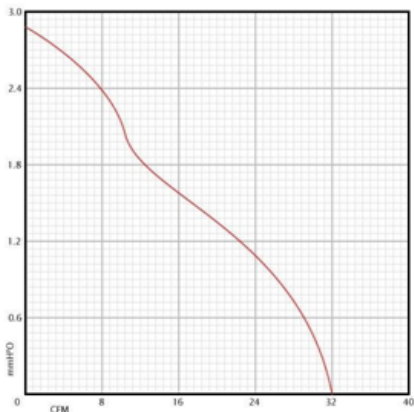

RoHS Certificate of Compliance:

As of February 2, 2006
 This "RoHS Certificate" provides information regarding the absence of certain substances in the Fan model listed on this document. The models identified below are in compliance with the European Union Directive 2002/95/EC on the restriction of use of certain hazardous substances ("RoHS Directive"). The models do not contain any of the restricted substances referred to in the European Union Commission Decision of August 18, 2006 (2005/618/EC) in connection with Articles 4 and 5 of the RoHS Directive in concentrations in excess of the values permitted thereunder.
 For purposes of this RoHS Certificate, the maximum concentration values of the restricted substances by weight of homogeneous materials are:
 hexavalent chromium 1,000 ppm
 poly-brominated biphenyls (PBB's) 1,000 ppm
 poly-brominated diphenyl ethers (PBDE's) 1,000 ppm
 cadmium 100 ppm
 mercury 1,000 ppm
 lead 1,000 ppm

Conforms to CE - Reference 73/23/EEC Low Voltage Directive.
 Fan housing and fan blade resin flammability conforms to class UL-94V-2.

Operation:

Mount in desired location for optimal cooling. Intakes are best positioned lower or adjacent to equipment. Exhausts are best positioned at the top or above equipment. Connect power.

Maintenance:

Cleaning the fan is the best preventative maintenance. Cleaning frequency would depend on the environment. It is recommended that the blade be cleaned to prevent any buildup of dust. Canned air works well.

Blade Removal:

For cleaning and maintenance, the blade prop can be removed.

Grasp the blade prop and pull straight out of the fan body. Inspect the shaft and lubricate if needed. Any oil will work; light grease works best. Clean blade as needed with a dry cloth. Soap and water can be used if needed, but should be thoroughly rinsed and dried before use. Reinstall the blade; when properly installed the blade will snap into place. Cleaning and inspection of the blade shaft should be done annually for best performance.

Warranty:

3 Years from the date of purchase.